

# Voltaire® Messaging Accelerator™ for Ethernet

## Achieve Lowest Latency for UDP Socket-Based Applications



### Overview

Voltaire Messaging Accelerator (VMA) is a dynamically-linked user-space Linux library for accelerating multicast traffic. Applications that utilize UDP multicast sockets use the library to offload network processing from a server's CPU. The traffic is passed directly to an Ethernet network interface card (NIC) from the application user space, bypassing the kernel and IP stack and thus minimizing context switches, buffer copies and interrupts, resulting in extremely lower latency transport performance.

Voltaire Messaging Accelerator for Ethernet provides the performance required for transaction-based applications through seamless Ethernet IP multicast connectivity, with application-to-application latency (RTT/2) as low as 4 microseconds. As a result, application performance is improved without having to modify application code.

### Dramatically Improving the Performance of Financial Market Data and Other Multicast Applications

Voltaire Messaging Accelerator boosts the performance of financial market data applications, including NYSE Technologies' DF, 29West LBM and RTI DDS, cutting latency by as much as 80% and increasing application throughput per server, as compared to applications running on standard Ethernet interconnect networks.

For example, a typical TCP/IP multicast application (in this case, market data) would function as illustrated in Figure 2. In contrast, as seen in Figure 3, using Voltaire Messaging Accelerator dramatically reduces the application latency by 95%.

### Features and Benefits

- **Transparency:** No application code changes required and fully compatible with Linux socket API
- **Connectivity:** Seamless Ethernet IP multicast connectivity over any standard Ethernet switch
- **Commodity hardware:** Implemented on standard commodity servers
- **Low jitter:** Minimizes maximum and average latencies
- **Lower latency:** Up to 300% faster
- **Higher throughput:** Up to 500% improvement; extremely high packet rate
- **Scalability:** Impressive results over thousands of nodes

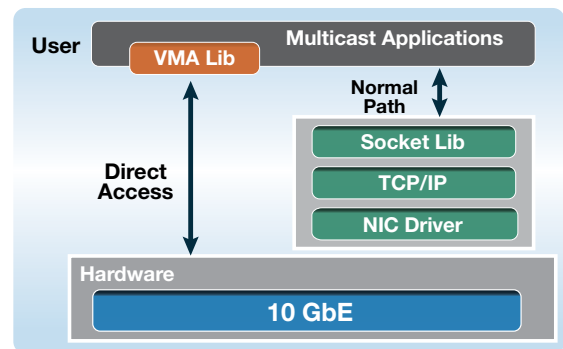

Figure 1: VMA Block Diagram

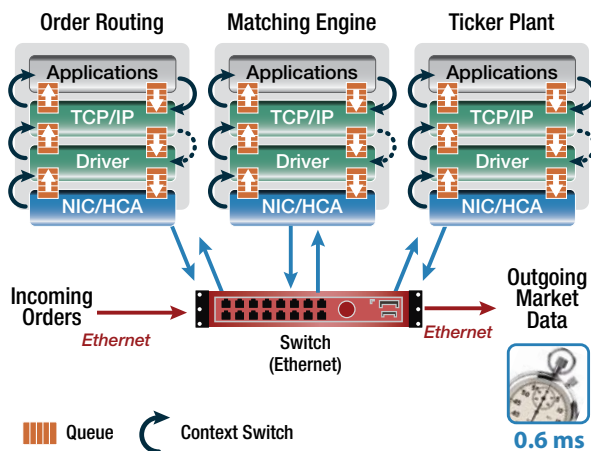

Figure 2: Poor Latency (0.6 milliseconds) with TCP/IP

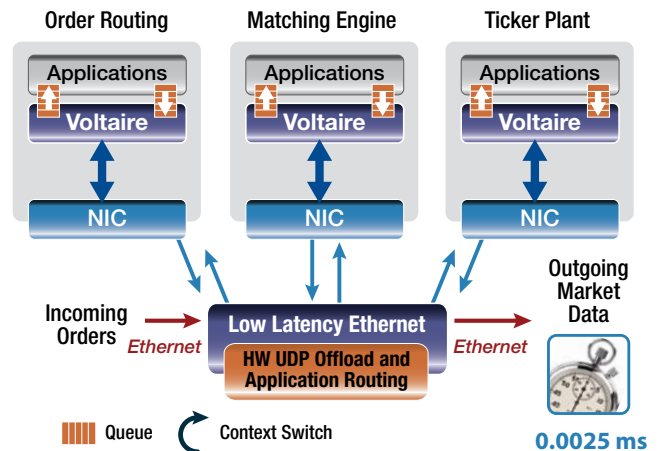

Figure 3: Cut Latency by 95% (0.0025 milliseconds) Using VMA

# Voltaire® Messaging Accelerator™ for Ethernet

Due to the transparent and high-performance nature of Voltaire Messaging Accelerator, many multicast applications with heavy traffic volumes and/or low messaging latency requirements gain a measurable increase in application performance. Ideal candidates for Voltaire Messaging Accelerator include:

- Market data feed handler software that consumes multicast data feeds and uses multicast as a distribution mechanism
- Messaging applications that produce or consume large amounts of multicast data including applications that utilize messaging middleware
- Caching/data distribution applications that utilize multicast for cache creation or to maintain data state
- Any data acquisition application (such as: radar and sonar, medical and imaging systems, etc.), which makes heavy use of multicast and requires high packet per second (PPS) rates, low data distribution latency, low CPU utilization or increased application scalability

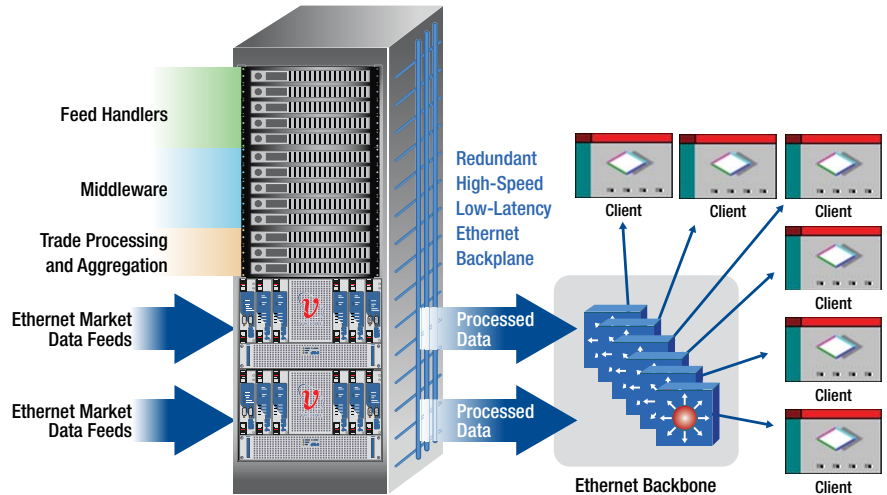

Figure 4: Implementing VMA for Multicast Applications

## As Data Volumes Increase, the Need for Low Latency Grows

As data volumes increase in a variety of enterprises, market segments and applications, Voltaire Messaging Accelerator becomes a popular choice for transparent improvement of multicast application performance.

Voltaire Messaging Accelerator is the ideal choice for enterprises that are seeking a low latency solution and prefer to avoid code changes or the use of additional hardware units. Notable results are achieved by bypassing the operating system and the UDP stack.

## Resiliency for Working in Complex Environments

Voltaire Messaging Accelerator supports multicast traffic, high volatility environments, variable message size, and burst resiliency, therefore boosting performance in complex environments. With Voltaire Messaging Accelerator, scalability to hundreds of nodes and thousands of subscriber processes is possible:

This is achieved by:

- Multicast acceleration using OS bypass and native multicast
- Minimizing context switches
- Standard Socket API without application modifications
- Less copy in standard socket API
- Minimizing jitter

One-Way Latency [Usec]

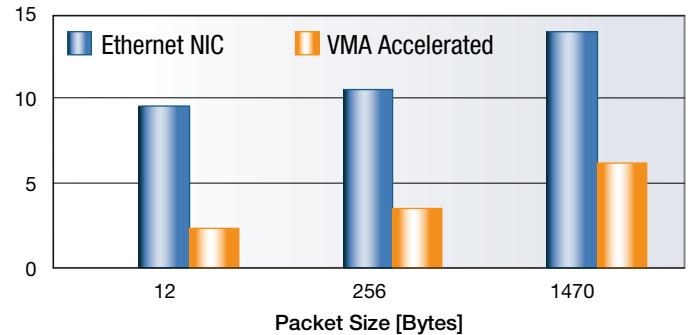

Figure 5: VMA Latency is 3X Lower than Without VMA (Source: internal ping-pong test)

Packet Rate (pps)

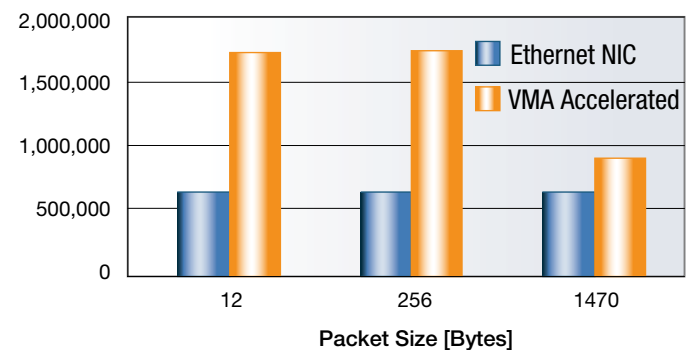

Figure 6: VMA runs 2X Faster than Standard Ethernet (Source: internal ping-pong test)



Contact Voltaire to Learn More

1.800.865.8247  
[info@voltaire.com](mailto:info@voltaire.com)  
[www.voltaire.com](http://www.voltaire.com)

©2010 Voltaire Inc. All rights reserved. Voltaire and the Voltaire logo are registered trademarks of Voltaire Inc. Grid Director is a trademark of Voltaire Inc. Other company, product, or service names are the property of their respective owners.

P/N: 00609 Rev. A01